

# Mobile sanitation solutions

Marine holding tank system

194 – 205

Portable toilets

206 – 207

Dometic CARE sanitation fluids

208 – 211

 **Dometic**  
THE SIGN OF COMFORT



## Undiminished holiday enjoyment

The Dometic sanitation solutions for yachts and boats

### A new dimension of mobile comfort and hygiene

Combining perfectly matching components, Dometic offers you the ideal solution for mobile hygiene. First of all, a retrofit holding tank system to get your boat ready for current European waste disposal regulations. Modern, portable toilets and innovative sanitation fluids add up to a comfort-enhanced concept for undiminished holiday enjoyment. Based on advanced technology and unique formulations, Dometic products ensure your mobile toilet is totally hygienic, free from unpleasant odours and very easy to clean.

Experience a new kind of mobile comfort and hygiene – with system solutions by Dometic.

## Waste holding tank system

Pages 194 – 205

Here's our answer to the new waste disposal regulations of the EU: the new Dometic waste holding tank system. This system solution was specifically designed for the European market and is very easy to retrofit. Well-engineered, durable quality components guarantee impeccable operation for many years.

### Dometic SANITATION

NEW



Holding tanks

Waste discharge pump

Vent filter

Tank level monitors

Tank discharge management

Hoses

## Portable toilets

Pages 206 – 207

The 970 series is particularly space-saving and easy to handle. The strong 360° pressure flush with push-button control ensures effective and powerful cleaning with less pumping. The extra-large flush water tank holds water for 27 flushes.

### Dometic 970 Series



972

976

## Dometic CARE hygiene system

Pages 208 – 211

Highest efficiency and environmental compatibility are the hallmarks of Dometic CARE sanitation fluids. For improved hygiene and a fresh scent in your bathroom. Application is safe and simple.

### Dometic CARE



SPECIAL CARE



POWER CARE



EXTRA CARE



QUALITY CARE



TANK CARE

NEW



## Clean water – a joint commitment

**Boats contribute a very small volume of the total pollution entering our waterways. But discharge of sewage leads to visual pollution and takes the fun out of boating and time on the beach. It also creates local problems if discharged near swimming beaches, shellfish beds, coral reefs and other eco-sensitive waters.**

Dometic is dedicated to a healthy marine environment. We promote the growing use of holding tanks and pump-out stations to keep marinas clean and compliant with coming requirements. Our role in this commitment is to provide on board sanitation equipment that is trouble-free and reliable. Join us in making a “clean water” commitment.



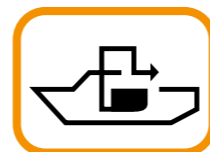

### Clean water in Europe

To allow boats to freely cruise over national borders without restriction due to onboard equipment requirements, the European Union is moving towards standardized regulations. Pan-European objectives, standards and measurements will be coming to restore and promote water quality. In fact, in the US all boats fitted with a toilet must be equipped with either a holding tank or a treatment device since the early seventies. There, we have produced over a quarter million holding tank systems for boats. We are now very proud to introduce a new line of holding tank systems especially designed for the European boat owner.

**Make a clean water commitment – Pump out!**



### Examples of important steps on a national level:

-  **Netherlands**  
From 1st of January 2009 release of black water from any type or recreational craft is prohibited. All existing yachts with toilets must be equipped with holding tanks or equivalent capability as of January 1st 2009.
-  **United Kingdom**  
Direct discharge of sewage into inland waters is prohibited. Codes of Best Practice are strongly encouraged.
-  **France**  
Recreational boats equipped with toilets and built after January 1st 2008 which enter maritime or inland ports must be equipped with an installation that permits either to store toilet water or treat it.
-  **Spain**  
All vessels built per May 2004 or later must have a holding tank installed.
- Baltic Sea**  
The Helsinki Convention for the protection of the Baltic Sea (HELCOM) recommends installation of toilet retention systems on all ships. The Recommendation must be taken up by national authorities.

### Will holding tanks result in cleaner water?

Yes. In 1988, the Avalon Harbor, California implemented a programme to prevent swimming beach closures due to bacterial pollution. A part of the programme was to promote holding tanks and pump-out stations and any boat caught discharging sewage was fined and banned from returning to the harbour. Due to the no-discharge programme, harbour water was improved and boats excluded as a potential cause of bacterial pollution.



### US leading by example

The Avalon Harbor campaign uses a very effective dye tablet enforcement program. By using a non-toxic dye marker any discharge of sewage is readily detected. In 2007, officers from The Florida Fish and Wildlife Conservation Commission (FWCC) started to use this tool to check onboard systems on boats coming into Florida.

**Ultimately – the most important result will be improved water quality that will give you and your family a better boating experience.**



A boat violating the no-discharge regulation – immediately detected by the dye

**OEM quality  
for retrofitting**







## Proven expertise – at your service

Dometic has been a leading system supplier for many years. The wealth of know-how and experience accumulated in numerous OEM projects with world leading boat builders and sanitation system installers forms the basis for our retrofit sanitation solution: a complete holding tank system specially designed for the European market.

To help boat owners meet current waste discharge legislation, the Dometic holding tank system is easy to install and provides reliable operation for many years. All components and accessories have proven their excellent quality thousands of times over. From high-performance discharge pumps combined with reliable tank level indicators and intelligent pump controls to odour-tight vent filters and sanitation hoses – the Dometic system solution has got it all covered.

### ISO 8099 – easy to comply with regulations

**This international standard defines the technical requirements for boat toilet retention systems. Dometic holding tank systems meet these requirements.**

- The vent pipe diameter should be at least 19 mm to withstand the suction pressure at the pump-out, or alternatively be equipped with a vacuum relief valve. 
- It must be visible when the tank is ¾ full [direct inspection or tank level indicator]. 
- For deck discharge connection a Ø 38 mm opening should be used. 
- Where sewage remains in the hose, an odour-tight type of hose should be used. 

#### A Holding tank

Stores sewage from toilet until it can be discharged at the dockside or at sea [depending on local regulations].

- Leak-proof, odour-free design in highly durable polyethylene
- Pre-installed and tested fittings for easy and safe installation
- Flexible inlet/outlet design
- Vacuum relief valve prevents damage from high-capacity dockside vacuum pumps
- Choice of 5 models ranging from 42 to 137 litres



#### E Discharge pump

- Self-priming pump, flow rate > 1000 l/h
- Long-life bellows design
- Quiet operation
- Runs dry without damage
- 2 models – 12 or 24 V DC



#### D Vent Filter

Stops odours from escaping through the holding tank vent.

- Unique odour-absorbing filter material
- No need to add chemicals to the holding tank
- Easy-to-replace filter cartridge



#### F MaxFlex sanitation hoses

- Very flexible hoses, easily installed and capable of handling a variety of sanitation uses
- Available in 16, 19, 25 and 38 mm diameters

#### G OdorSafe Plus sanitation hose

- Best odour barrier of any marine hose available
- 38 mm diameter for sewage systems



#### H Fittings

- For holding tank system plumbing, connection and repair

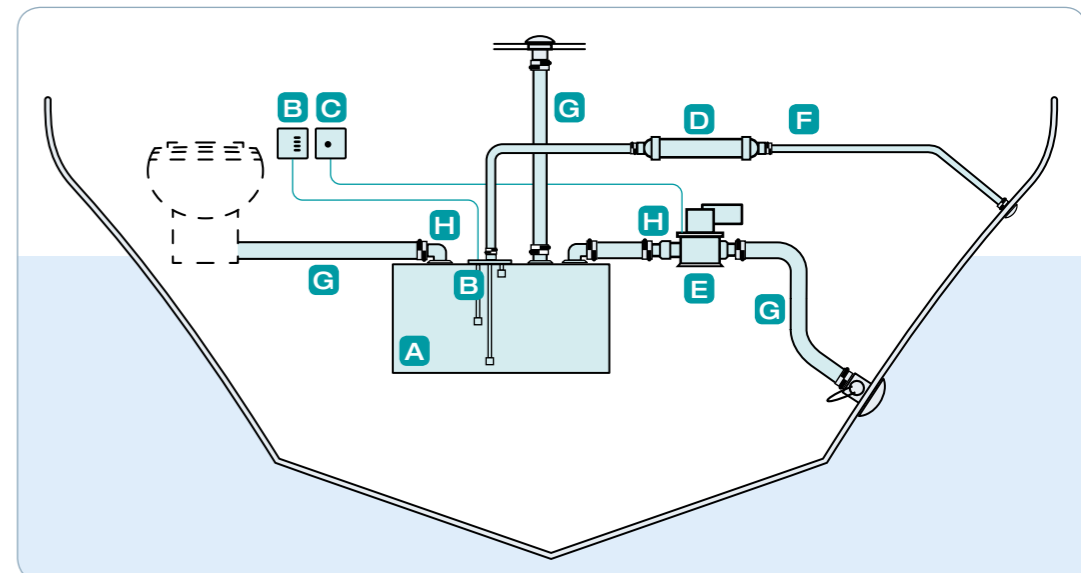

#### C Tank Discharge Control

- Connects to DTM04 tank monitor
- Manual tank discharge in unrestricted waters [Manual "On", Automatic "Off"]
- Prevents accidental overboard discharge in restricted waters



#### B Tank monitors

For checking the holding tank level.

- DTM01C – single-level unit with red warning light, indicates when holding tank is full
- DTM04 – four-level unit with four-colour LED, indicates if holding tank is empty, low, mid or full





**Odour-free and leak-proof**

## A clean and easy solution to fit every boat

Tried and tested in thousands of installations, Dometic holding tanks provide a clean and safe service for many years. Top-mounted hose connections and an extra-thick wall of durable polyethylene give a leak-proof and odour-free design. Handy for do-it-yourself enthusiasts: all holes are pre-cut, all fittings are pre-installed and tested in the factory. Two separate discharge outlets eliminate the need for extra plumbing connections. Add to this a comprehensive range of well-planned accessories [p. 200 – 207], and you'll get an all-in-one, no-worry solution.

Dometic holding tanks are available in five sizes to fit all common types of boats.

- Leak-proof, odour-free design in highly durable polyethylene
- Pre-installed and tested fittings that can rotate
- Separate outlets for dockside and overboard discharge
- Discharge tubes in special non-clogging design
- Level indicator, discharge controls are easily retrofitted
- Vacuum relief valve prevents damage from high-capacity dockside vacuum pumps
- Compliant with ISO 8099 requirements
- 5 year warranty

### Superior design: extra-thick walls, efficiently dip tube outlet

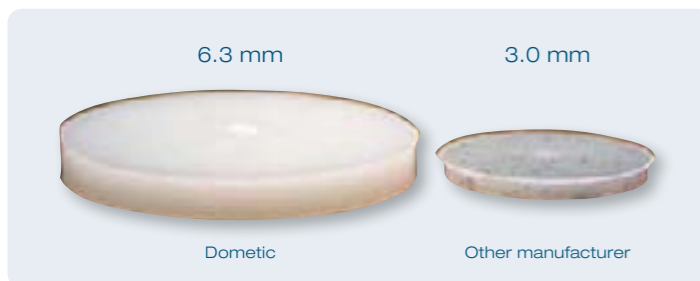

Outstanding wall thickness:  
Absolutely leak-proof and odour-tight with 6.3 mm wall



The test shows:  
Unique dip tube design ensures the most efficient discharging.

## Dometic SANITATION DHT42L / DHT61L / DHT88L / DHT110L / DHT137L

7.04

Holding tank for use with marine toilets

Available in 5 sizes: 42, 61, 88, 110 and 137 litres

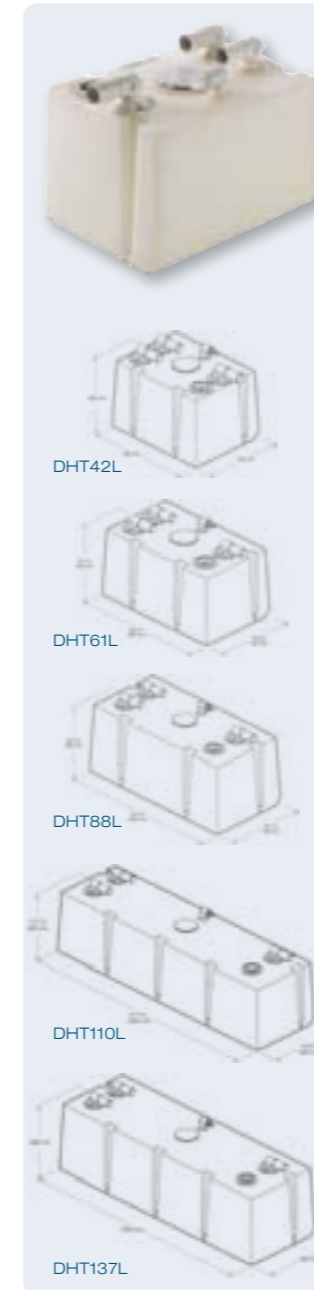

<b>Gross capacity</b>	DHT42L: 42 litres DHT61L: 61 litres DHT88L: 88 litres DHT110L: 110 litres DHT137L: 137 litres
<b>Material</b>	Holding tank: polyethylene Fittings: polyvinyl chloride, ABS
<b>Colour</b>	Holding tank: natural Fittings: white
<b>Dimensions [W x H x D]</b>	DHT42L: 460 x 347 x 350 mm DHT61L: 660 x 348 x 350 mm DHT88L: 800 x 388 x 400 mm DHT110L: 1200 x 348 x 350 mm DHT137L: 1200 x 388 x 400 mm
<b>Empty weight</b>	DHT42L: 5.4 kg DHT61L: 7.7 kg DHT88L: 10.2 kg DHT110L: 14 kg DHT137L: 14.5 kg
<b>Quality features</b>	Leak-proof, odour-free design in highly durable polyethylene [6.3 mm wall thickness], pre-cut holes, pre-installed and tested fittings that can rotate, two separate outlets for dockside and overboard discharge, vacuum relief valve prevents damage from high-capacity dockside vacuum pumps
<b>Test mark</b>	ISO 8099 compliant

**NEW**

Odour-free, leak-proof design

Easy installation with pre-assembled fittings

Vacuum relief valve for safe dockside discharge

Available in five sizes to suit virtually all types of boats

Wide choice of accessories [p. 198 – 205]

**5 year warranty\***

**Scope of delivery:** holding tank, 2 outlet fittings [Ø 38 mm], 1 inlet fitting, 1 vent fitting [Ø 16 mm], pressure relief valve, inspection port with cap, instruction manual, bag of spare fittings [inlet fitting, sealing grommet, plug, hose lubricant]

Product	Ref. No.
Dometic SANITATION DHT42L	9107100001
Dometic SANITATION DHT61L	9107100002
Dometic SANITATION DHT88L	9107100003
Dometic SANITATION DHT110L	9107100004
Dometic SANITATION DHT137L	9107100005

\* Due to the holding tank's heavy-duty wall and the integrated vacuum relief valve, the DHT-L Series comes with a five-year warranty against cracking or leaking.

### Pre-installed and tested fittings for easy and safe installation



- 1 Outlet to deck fitting or discharge pump
- 2 Outlet to deck fitting or discharge pump
- 3 Inspection port [and location of optional level indicator]
- 4 Ventilation connection
- 5 Vacuum relief valve
- 6 Inlet from toilet

**Pre-fitted and pre-tested**



## “Fit-and-forget” pump design

Dometic DTW-series waste discharge pumps are based on a unique bellows design that makes them last longer than other manufacturers’ rubber diaphragm pumps. Running quietly, they easily handle over 1000 litres of waste per hour. Available for either 12 or 24 volts DC.

- Long-life bellows design
- Quiet operation
- Runs dry without damage
- Handles liquids and solids

### Dometic SANITATION DTW12 / DTW24

Holding tank discharge pump for 12 or 24 volts DC

7.04



<b>Flow rate</b>	1130 litres per hour
<b>Voltage</b>	DTW12: 12 volts DC DTW24: 24 volts DC
<b>Current input</b>	DTW12: 6 A DTW24: 3 A
<b>Required circuit protection</b>	DTW12: 10 A breaker/fuse DTW24: 5 A breaker/fuse
<b>Hose connection</b>	38 mm ID sanitation hose
<b>Material</b>	Pump body: glass-filled polypropylene Bellows: engineered PE/PP resin Valves: EPDM
<b>Colour</b>	White
<b>Dimensions [W x H x D]</b>	349 x 197 x 171 mm
<b>Weight</b>	3.5 kg
<b>Quality features</b>	Robust, long-life pump design, runs dry without damage, handles liquids and solids, thermally protected motor, quiet operation
<b>Test marks</b>	ISO 8846, EMC Directive 2004/108/EC

**Scope of delivery:** waste discharge pump, instruction manual

Products	Ref. No.
Dometic SANITATION DTW12	9107100006
Dometic SANITATION DTW24	9107100007

**NEW**

Quiet operation

Choice of two models for 12 or 24 volts DC

Long-lasting bellows design

**5 year warranty\***

\* Due to the unique bellows design, we offer a five-year warranty on the bellows against wear-out.



## For a pleasant breeze of fresh air

Looking for an effective means to stop odours escaping through the holding tank vent? The Dometic vent filter uses a unique filter material that captures heavier-than-air gases. It keeps your boat smelling clean and pleasant without any chemicals added to the tank. Each cartridge is good for an entire season, and is easily replaced.

- Specially formulated odour-removing filter material
- No need to add chemicals to the holding tank
- Easy-to-replace filter cartridge
- Supplied with installation fittings and hose adapters [Ø 16 and 19 mm]

### Dometic SANITATION DVF1619

Holding tank vent filter [Ø 16 mm or 19 mm]

Stops odours from escaping through the holding tank vent

7.04



<b>Material</b>	Filter media: granular Activated Carbon [GAC] Vent filter casing: PVC Hose adapters: polypropylene Mounting bracket: polypropylene
<b>Colour</b>	Vent filter: grey Hose adapters: white Mounting bracket: white
<b>Dimensions [W x H x D]</b>	400 x 80 x 80 mm
<b>Weight</b>	1.0 kg
<b>Quality features</b>	Specially formulated filter material eliminates odours by capturing heavier-than-air gases, no need for toilet chemicals to control odours in the holding tank, filter cartridge is easily replaced without touching filter media

**Scope of delivery:** vent filter, two 16 mm hose adapters, two 19 mm hose adapters, mounting bracket, two fasteners, instruction manual

Product	Ref. No.
Dometic SANITATION DVF1619	9107100008

**NEW**

Unique odour-absorbing filter material

Eliminates the need for holding tank chemicals

Includes adapters for 16 and 19 mm hoses

**Do not use with chlorine-activated waste treatment systems**



## Tank level check at a glance

A technology used by the world's leading boat builders: Dometic tank level monitors give you unparalleled reliability and ease of use. A single glance is enough to check the available tank capacity – no false readings, no confusion possible. The DTM01C basic model uses a red warning light to indicate when the tank is near full. More detailed information is provided by the DTM04 comfort model, which indicates empty, low, mid and full levels on a four-colour display. Both units are very easy to install. Simply remove your holding tank's inspection port cap and replace it with the float switch assembly of your tank monitor.

- Highly reliable and proven technology, installed by leading boat builders
- Single-glance tank level check
- Choice of two models: single-level or four-level indicator
- Safe to use: no false readings, no confusion, no electrical components in contact with water
- Operation on 12 or 24 volts DC
- DTM04 tank monitor pre-wired for optional relay to shut down electric toilets when the tank is full

### Dometic SANITATION DTM01C

Tank monitor  
Single-level unit with one float switch and red warning light

7.04



<b>Voltage</b>	12/24 volts DC
<b>Current input</b>	16 mA
<b>Required circuit protection</b>	0.5 A breaker/fuse
<b>Material</b>	Frame: ABS Panel: polyester Cap: PVC Float: nitrile rubber ebonite
<b>Colour</b>	Frame and panel: black Cap: white
<b>Dimensions [ W x H x D ]</b>	83 x 51 x 10 mm
<b>Weight</b>	1.0 kg
<b>Quality features</b>	Highly reliable float switch, activates red warning light when holding tank is approx. ¾ full. Easy installation on Dometic holding tanks in place of the inspection port cap.
<b>Test marks</b>	ISO 8846, EMC Directive 2004/108/EC

**Scope of delivery:** single float switch assembly with cap, display panel with one light

Product	Ref. No.
Dometic SANITATION DTM01C	9107100009

**NEW**

Simple and cost-effective solution

Reliable, well proven design

Easy installation

### Dometic SANITATION DTM04

Tank monitor  
Four-level unit with three float switches and four-colour LED

7.04



<b>Voltage</b>	12/24 volts DC
<b>Current input</b>	12 volts DC: 8 mA 24 volts DC: 4 mA
<b>Required circuit protection</b>	1 A breaker/fuse
<b>Material</b>	Frame: ABS Panel: polycarbonate resin Cap: PVC Float: nitrile rubber ebonite
<b>Colour</b>	Frame and panel: black Cap: white
<b>Dimensions [ W x H x D ]</b>	Panel: 83 x 83 x 10 mm
<b>Weight</b>	1.0 kg
<b>Quality features</b>	Highly reliable unit with three pre-adjusted float switches, holding tank level indicated by four-colour LED [empty, low, mid, full]. Easy installation on Dometic holding tanks in place of the inspection port cap. Pre-wired for connection of optional relay to shut down electric toilets when tank is full.
<b>Test marks</b>	ISO 8846, EMC Directive 2004/108/EC

**Scope of delivery:** cap with three level switches, display panel with four lights, instruction manual

Product	Ref. No.
Dometic SANITATION DTM04	9107100010

**NEW**

Comfort model with four-level indication

Highly reliable design – no confusion, no false readings

Easy installation

Adjustment of float switch to required length possible



## Comfortable tank discharge management

For extra comfort and convenience you can combine the DTM04 tank monitor with Dometic's automatic tank discharge control. This easy-to-use control system allows you to turn on the discharge pump anytime. When the keyed control switch is set to the automatic mode the discharge pump is activated as soon as the holding tank reaches mid level. In the manual mode you can turn on the discharge pump directly – provided you are sailing in unrestricted waters. Once you enter a "No-Discharge Zone" the tank discharge control must be switched to the OFF position to prevent accidental discharge.

- Convenient holding tank discharge: no need to remove hatches or reach for inaccessible valves
- Prevents accidental overboard discharge in restricted waters when switched to OFF position
- Manual pump activation possible anytime in unrestricted waters
- Simplifies plumbing by eliminating Y-valves, seacocks and vented loops

### Dometic SANITATION DTD01-12 / DTD01-24

Tank discharge control

For use in combination with DTM04 tank monitor

7.04



<b>Voltage</b>	DTD01-12: 12 volts DC DTD01-24: 24 volts DC
<b>Current input</b>	0.16 A
<b>Required circuit protection</b>	1 A breaker/fuse
<b>Material</b>	Frame: ABS Panel: polycarbonate resin
<b>Colour</b>	Black
<b>Dimensions [W x H x D]</b>	83 x 83 x 10 mm
<b>Weight</b>	1.0 kg
<b>Quality features</b>	Keyed control switch for automatic or manual tank discharge, prevents accidental discharge in restricted waters when in OFF position.
<b>Test marks</b>	ISO 8846, EMC Directive 2004/108/EC

**Scope of delivery:** electric discharge control panel, 2 x keys, instruction manual

Product	Ref. No.
Dometic SANITATION DTD01-12	9107100011
Dometic SANITATION DTD01-24	9107100012

**NEW**

Easy and safe holding tank discharge

Manual discharge in unrestricted waters

No accidental discharge in restricted waters

Simplifies plumbing by eliminating Y-valves

## Fittings for all plumbing situations

Dometic offers just about all the fittings you might need when connecting your retrofit holding tank system to your on-board toilet. From hose reducers to match the size of the toilet outlet, through Wye kits and Tee pieces for connecting a second toilet to the holding tank inlet, to elbow kits for small bending radiuses and hose menders for maintenance and repair – there's a matching product for all plumbing situations.

All fittings are designed for use with Dometic SANITATION OdorSafe Plus 38 hose [see page 205].

### Dometic SANITATION Accessories

Fittings for holding tank system plumbing

For connection and repair of 38 mm hose in a sanitation system

7.04

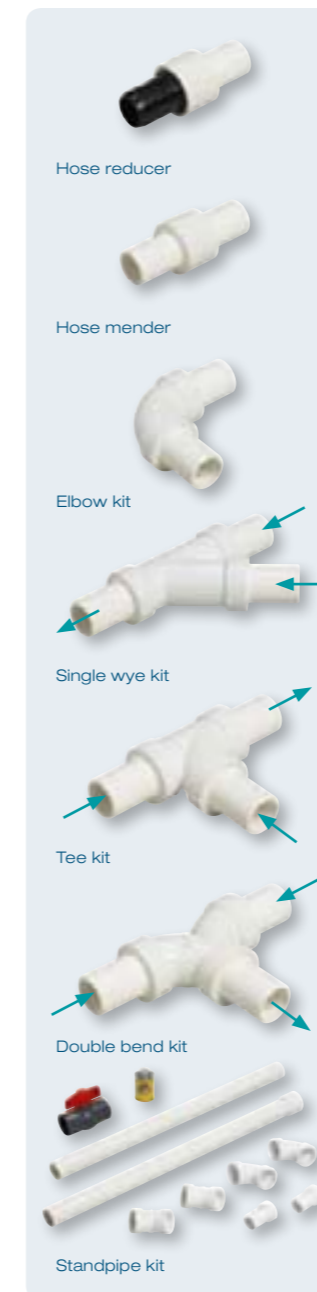

#### Products and uses

##### Hose reducers

Connect 38 mm hose to 25 mm hose  
Connect 40 mm hose to 38 mm hose

##### Hose mender

Connects 38 mm hose segments for repair or maintenance

##### Elbow kit

Provides smooth sweep bend, eliminates hose kinks  
To be used when bending radius is less than 210 mm

##### Single Wye kit

Connects intersecting 38 mm hose segments per indicated flow [see picture]

##### Tee kit

Connects intersecting 38 mm hose segments per indicated flow [see picture]

##### Double bend kit

Connects intersecting 38 mm hose segments per indicated flow [see picture]

##### Standpipe kit

Install where you need to eliminate a sewage hose run.  
Kit includes two lengths of 38 mm PVC pipe, various fittings, one ball valve for maintenance purposes, PVC cement and gluing instructions.

**Material** Polyvinyl chloride

**Colour** White

Product	Ref. No.
40 mm x 38 mm Hose reducer	9107100026
38 mm x 25 mm Hose reducer	9107100022
38 mm x 38 mm Hose mender	9107100020
38 mm Elbow kit	9107100021
38 mm Single wye kit	9107100024
38 mm Tee kit	9107100025
38 mm Double bend kit	9107100023
Standpipe kit	9107100027

**NEW**

High quality, long life fittings

Compatible with OdorSafe Plus 38 hose [p. 205]

**Pre-glued and tested**





## Best-in-class hose design

Dometic marine hoses are the result of extensive research and continuous feedback from boat owners and sanitation system installers. There's a perfect solution for every application. MaxFlex sanitation hoses, living up to their name, provide maximum flexibility in every respect. They easily bend around tight corners while maintaining the full inside diameter. Available in four sizes, they can be used for toilet, pump and tank connections as well as on vent systems.

The OdorSafe Plus hose offers the best odour barrier of any hose available in the marine industry. Lab tests have shown up to 500% greater resistance to odour permeation than other manufacturers' so-called "no-odour" hoses!

### MaxFlex sanitation hose

- Very flexible hose, easy to install even in confined spaces
- Suitable for multiple sanitation uses
- Available in four sizes [Ø 38, 25, 19 and 16 mm]

### OdorSafe Plus sanitation hose

- Best odour barrier of any marine hose available
- Up to 500% greater resistance to odour permeation than other so-called "no-odour" marine hoses
- Five years warranty
- Available in 38 mm diameter for waste line

## Dometic SANITATION MaxFlex 38 / 25 / 19 / 16

Very flexible, high-quality hose for multiple sanitation uses  
Available in four sizes: Ø 38 mm, Ø 25 mm, Ø 19 mm and Ø 16 mm

7.04



<b>Material</b>	Flexible polyvinyl chloride
<b>Colour</b>	White
<b>Operating pressure</b>	<b>MaxFlex 38:</b> 4 bar <b>MaxFlex 25:</b> 6 bar <b>MaxFlex 19:</b> 8 bar <b>MaxFlex 16:</b> 8 bar
<b>Diameter [Ø] inner / outer</b>	<b>MaxFlex 38:</b> 39 mm / 47 mm <b>MaxFlex 25:</b> 26 mm / 32 mm <b>MaxFlex 19:</b> 20 mm / 24 mm <b>MaxFlex 16:</b> 17 mm / 22 mm
<b>Wall thickness</b>	<b>MaxFlex 38:</b> 4.1 mm <b>MaxFlex 25:</b> 2.9 mm <b>MaxFlex 19:</b> 2.3 mm <b>MaxFlex 16:</b> 2.6 mm
<b>Inside bend radius</b>	<b>MaxFlex 38:</b> 152 mm <b>MaxFlex 25:</b> 102 mm <b>MaxFlex 19:</b> 78 mm <b>MaxFlex 16:</b> 65 mm
<b>Hose length</b>	15 m
<b>Weight [g/m]</b>	<b>MaxFlex 38:</b> 700 g <b>MaxFlex 25:</b> 340 g <b>MaxFlex 19:</b> 200 g <b>MaxFlex 16:</b> 190 g
<b>Working temperature</b>	-17°C to +65°C
<b>Quality features</b>	Very flexible hose, easy installation, suitable for multiple sanitation uses [38 mm best for toilet, pump and tank connections; 25 mm commonly used on some electric marine toilets; 19 mm and 16 mm commonly used on vent systems]. Not for potable water

Scope of delivery: 15 m coil

Product	Ref. No.
Dometic SANITATION MaxFlex 38	9107100016
Dometic SANITATION MaxFlex 25	9107100017
Dometic SANITATION MaxFlex 19	9107100018
Dometic SANITATION MaxFlex 16	9107100019

**NEW**

Extremely flexible hose

Easy to install

Suitable for many sanitation uses

## Dometic SANITATION OdorSafe Plus 38

Sanitation hose with excellent odour barrier properties  
Available in Ø 38 mm for sewage system

7.04



<b>Material</b>	Flexible polyvinyl chloride
<b>Colour</b>	White
<b>Operating pressure</b>	6 bar
<b>Diameter [Ø] inner / outer</b>	38 mm / 47 mm
<b>Wall thickness</b>	4.1 mm
<b>Inside bend radius</b>	190.5 mm
<b>Hose length</b>	15 m
<b>Weight [g/m]</b>	710 g
<b>Working temperature</b>	-17°C to +65°C
<b>Quality features</b>	Excellent odour barrier, up to 500% more effective than other sanitation hoses, available in Ø 38 mm for sewage systems, PVC anti-crash spiral, no friction and no risk of clogging thanks to smooth inside surface

Scope of delivery: 15 m coil

Product	Ref. No.
Dometic SANITATION OdorSafe Plus 38	9107100015

**NEW**

Most odour-resistant hose available in the marine market

**5 year warranty**



## Home-like comfort: the new 970 series

**Small, but a big performer:** handy and space-saving, the new 970 series adds hygienic comfort to your boat. Many sensible functions are contained in the smallest possible space to ensure you enjoy home-like comfort on your cruise.

- Portable toilet in two sizes and two colours
- Push-button control for powerful flushing with less pumping
- Extra-strong 360° pressure flush for effective cleaning
- 8.7-litre flush water tank – sufficient for 27 flushes
- Safety through overflow protection and tank level indicator
- Ingenious disposal system: extra-long, pivoting spout and vent openings for clean, splash-free discharge
- Useful accessories: spare tanks, discharge kits, fixing kit

### A firm hold on hygiene

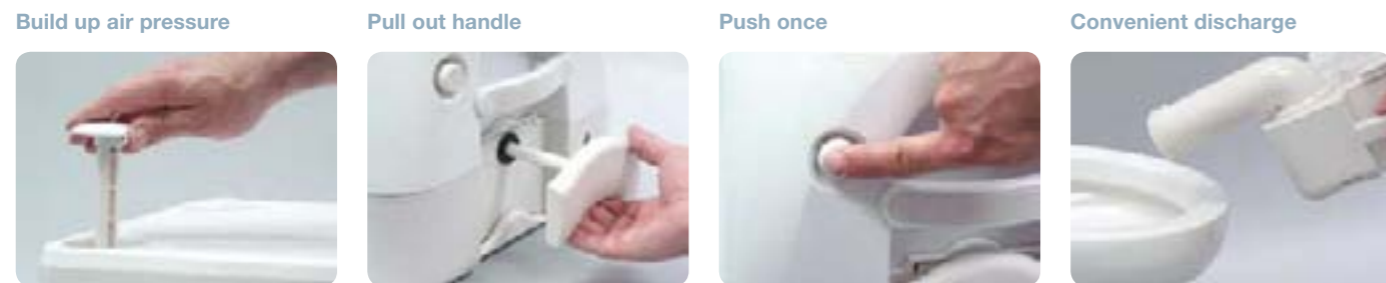

### Dometic 970 series

Space-saving portable toilets with 360° pressurised flush

7.01



972	
Flush water tank capacity	8.7 litres
Waste tank capacity	9.8 litres
Material	ABS
Colour	White/beige or white/grey
Dimensions [WxHxD]	333 x 317 x 387 mm
Weight	5.4 kg
976	
Flush water tank capacity	8.7 litres
Waste tank capacity	18.9 litres
Material	ABS
Colour	White/beige or white/grey
Dimensions [WxHxD]	333 x 387 x 387 mm
Weight	5.9 kg

Product	Ref. No.
Dometic 972, white/beige	958042350
Dometic 972, white/grey	958042351
Dometic 976, white/beige	958042352
Dometic 976, white/grey	958042353

8.7-litre flush water tank – sufficient for 27 flushes

Extra-strong 360° pressurised flush for effective cleaning

Tank level indicator

Attractive design

### Accessories for Dometic 970 series

7.01

#### Spare tanks



	DTK972	DTK976
Waste holding tank capacity	9.8 litres	18.9 litres
Material	ABS	ABS
Colour	Grey	grey
Dimensions [WxHxD]	333 x 190 x 387 mm	333 x 270 x 387 mm
Weight	1.8 kg	2.3 kg

Product	Ref. No.
Dometic DTK972	9107100030
Dometic DTK976	9107100031

Ideal for use as standby holding tank

#### Discharge kits



	MSD972	MSD976
Material	PVC	PVC
Colour	White	White
Weight	0.14 kg	0.16 kg

Product	Ref. No.
Dometic MSD972	9107100028
Dometic MSD976	9107100029

Discharge kits for dockside disposal according to ISO 8099

#### Fixing kit



For easy and safe installation

Product	Ref. No.
Fixing kit for 970 series	385320005



## Dometic CARE – high-quality sanitation chemicals

**Supreme efficiency and environmental compatibility** are the hallmarks of Dometic CARE sanitation chemicals. The innovative products improve hygiene and create a fresh smell on board your yacht or boat. High-quality, ecologically compatible formulations provide an outstanding cleaning effect. Dometic **CARE** – the perfect solution for efficient operation of your sanitation equipment keeping it looking as good as new.

### **Dometic** SPECIAL CARE

**Ecologically compatible additive for the waste holding tank.**

Waste can be disposed at almost every pump-out station.

- Outstanding odour protection
- Facilitates waste storage and discharge
- Eco-friendly – awarded with ecological hallmark
- Pleasant, fresh scent



### **Dometic** POWER CARE

**Highly effective additive for the waste holding tank.** Breaks down waste into liquid and prevents unpleasant odours.

- Prevents the emergence of gas and unpleasant odours in the holding tank
- Breaks down waste into liquid to facilitate disposal
- Remains effective after freezing and thawing
- Simple dosing with measuring strip



### **Dometic** EXTRA CARE

**Fluid additive for the flush water tank.**

Can be used on its own or in combination with other Dometic toilet additives.

- Creates a smoother flush
- Prevents stains and scaling
- Protects the rubber seals
- Micro-thin protective layer facilitates cleaning of the toilet bowl
- Integrated deodoriser adds a pleasant fragrance



### **Dometic** QUALITY CARE

**Highly effective toilet bowl cleaner.**

Ideal for china and ceramics, but also for plastic and fibre glass.

- Efficient cleaning, brilliant results
- Quickly removes stains and scaling from the toilet bowl
- Creamy consistency, adheres to the bowl
- Simply apply to the bowl and under the rim, let it work, then brush it away

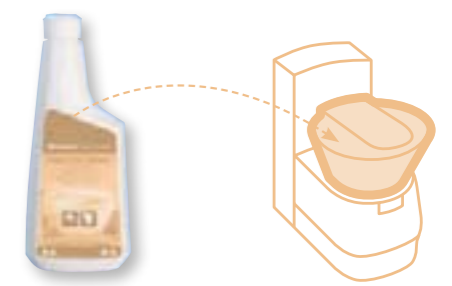

### **Dometic** TANK CARE

**Highly efficient additive for regular cleaning of the waste holding tank.**

Removes organic and inorganic scale from the tank's inner walls and components.

- Effortless cleaning: simply add it to the tank and let it work
- Economical dosing: **only 150 ml** additive for one cleaning
- Thorough cleaning, pleasant freshness





## Dometic CARE – the unique hygiene system for your mobile toilet

**Innovative research makes it possible: cleanliness in every micropore!** As effective as needed, as gentle on the environment as possible. The innovative **Dometic CARE effect** of Dometic CARE products eliminates dirt and toilet odours – creating a new dimension of mobile hygiene. Application is safe and simple.



### Clean air – pleasant scent

You can smell, too, just how safe and efficient the Dometic CARE hygiene system is: at long last there is a fresh scent in your mobile bathroom. **Dometic CARE is cleanliness to depend on in every respect.**

**Fresh-smelling, powerful toilet chemicals** – perfectly matching, they provide an innovative system of hygienic cleanliness



### Dometic CARE



Dometic SPECIAL CARE

#### Dometic SPECIAL CARE

**Ecologically compatible additive for the waste holding tank. Waste can be disposed at almost pump-out station.**

- Outstanding odour protection
- Facilitates waste storage and discharge
- Eco-friendly – awarded with ecological hallmark
- Pleasant, fresh scent

**Content** 1.5 litres



Dometic POWER CARE

#### Dometic POWER CARE

**Highly effective additive for the waste holding tank. Breaks down waste into liquid and prevents unpleasant odours.**

- Prevents the emergence of gas and unpleasant odours in the holding tank
- Breaks down waste into liquid to facilitate disposal
- Remains effective after freezing and thawing
- Indispensable for winter campers
- Simple dosing with measuring strip

**Content** 1.5 litres



Dometic EXTRA CARE

#### Dometic EXTRA CARE

**Fluid additive for the flush water tank. Can be used on its own or in combination with other Dometic toilet additives.**

- Creates a smoother flush
- Prevents stains and scaling
- Protects the rubber seals
- Micro-thin protective layer facilitates cleaning of the toilet bowl
- Integrated deodoriser adds a pleasant fragrance

**Content** 1.5 litres



Dometic QUALITY CARE

#### Dometic QUALITY CARE

**Highly effective toilet bowl cleaner. Ideal for china and ceramics, but also for plastic and fibre glass.**

- Efficient cleaning, brilliant results
- Quickly removes stains and scaling from the toilet bowl
- Creamy consistency, adheres to the bowl
- Simply apply to the bowl and under the rim, let it work, then brush it away

**Content** 0.473 litres

**NEW**



Dometic TANK CARE

#### Dometic TANK CARE

**Highly efficient additive for regular cleaning of the waste holding tank. Removes organic and inorganic scale from the tank's inner walls and components.**

- Effortless cleaning: simply add it to the tank and let it work
- Economical dosing: **only 150 ml** additive for one cleaning
- Thorough cleaning, pleasant freshness

**Content** 0.475 litres

Product	Ref. No.
Dometic SPECIAL CARE, 1.5 l	910720003
Dometic POWER CARE, 1.5 l	910720002
Dometic EXTRA CARE, 1.5 l	910720001
Dometic QUALITY CARE, 0.473 l	910720004
Dometic TANK CARE, 0.475 l	910720015

7.03

Total hygiene for your mobile toilet

Especially fresh and pleasant odour